



# BT tyro

## Powered pallet truck

---

The BT Tyro SHE100 is the new entry-level stacker model, perfect for light stacking applications.

It can transport and lift loads up to 1000 kg. The SHE100 is available with Li-ion technology for simplicity of use and energy-efficiency. It combines the features of a powered stacker truck with the small size of a manual stacker.

The BT Tyro Stacker is the perfect solution for manual and semi-powered stacker truck users who want to step-up to a fully powered stacker

# Dimensional Drawings

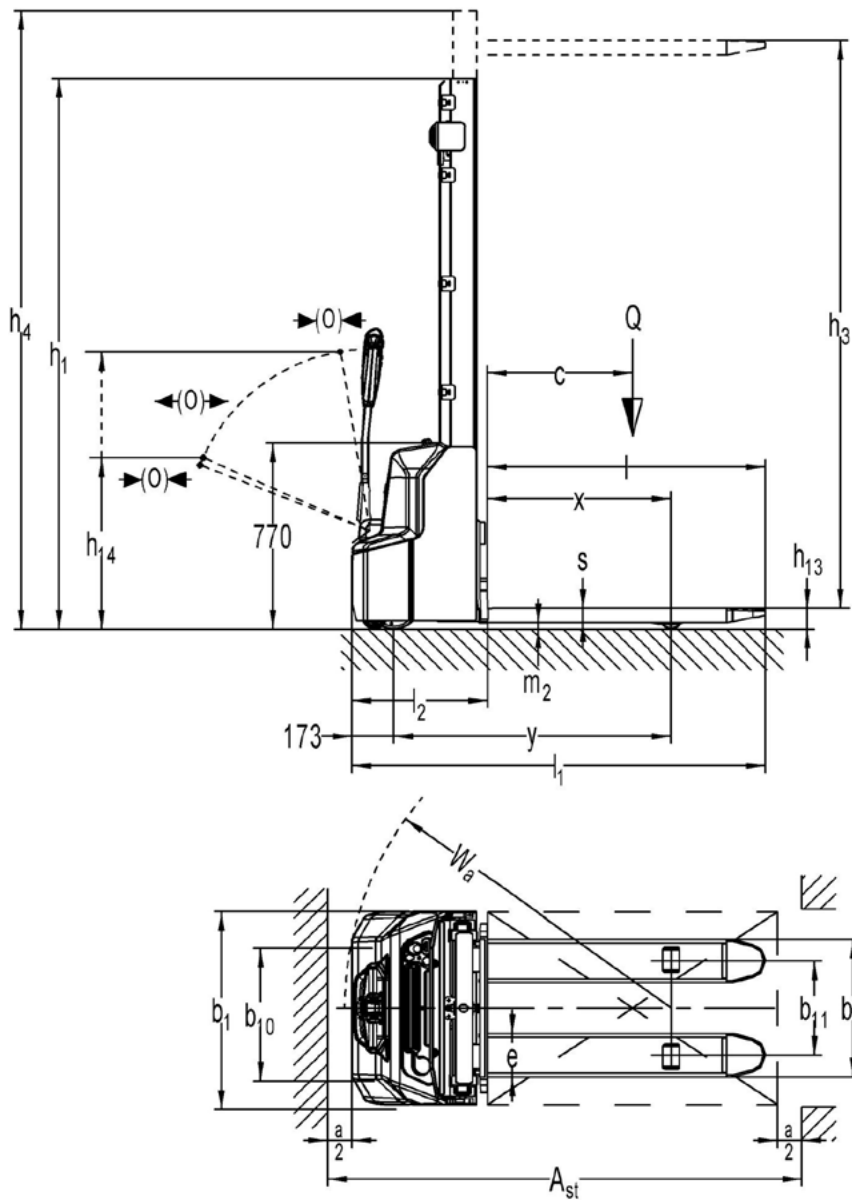

# Features



Distinguishing mark	1.2	Model		SHE100	
				h23 = 2900	h23 = 3600
	1.3	Drive		Battery	
	1.4	Operator type		Pedestrian	
	1.5	Load Capacity / rated load	Q (t)	1.0	
	1.6	Load centre distance	c (mm)	600	
	1.8	Load distance, centre of drive axle to fork	x (mm)	760	
	1.9	Wheelbase	y (mm)	1147	
Weight	2.1	Service weight	kg	565	594
	2.2	Axle loading, laden front/rear	kg	565 / 1000	575 / 1019
	2.3	Axle loading, unladen front/ rear	kg	435 / 130	455 / 139
Tires, chassis	3.1	Tires		Polyurethane	
	3.2	Wheel size, front	Ø x w (mm)	210x70	
	3.3	Wheel size, rear	Ø x w (mm)	84 x 93	
	3.4	Additional wheels, dimensions	Ø x w (mm)	100 x 50	
	3.5	Wheels, number front/ rear (x=driven wheels)		1x + 1 / 2	
	3.6	Track width, front	b10 (mm)	550	
	3.7	Track width, rear	b11 (mm)	400 / 515	
Dimensions	4.2	Lowered mast height	h1 (mm)	1930	2280
	4.3	Free Lift height	h2 (mm)	-	-
	4.4	Lift height	h3 (mm)	2814	3514
	4.5	Extended mast height	h4 (mm)	3337	4037
	4.9	Height of tiller in drive position, min./max.	h14 (mm)	710 / 1150	
	4.15	Height, fork lowered	h13 (mm)	86	
	4.19	Overall length	l1 (mm)	1710	
	4.20	Length to face of forks	l2 (mm)	560	
	4.21	Overall width	b1 (mm)	800	
	4.22	Fork dimensions	s/e/l (mm)	60 / 180 / 1150	
	4.25	Width over forks	b5 (mm)	570 / 685	
	4.32	Ground clearance, centre of wheelbase	m2 (mm)	1350	
	4.34.1	Aisle width for pallets 1000x1200 crossways	Ast (mm)	2197	
	4.34.2	Aisle width for pallets 800x1200 lengthways	Ast (mm)	2145	
	4.35	Turning radius	Wa (mm)	1350	
Performance	5.1	Travel speed, with/without load	km/h	4,2 / 4,5	
	5.2	Lift speed, with/without load	m/s	0,11 / 0,16	
	5.3	Lowering speed, with/without load	m/s	0,13 / 0,11	
	5.8	Max. gradeability, with/without load	%	5 / 10	
	5.10	Service brake		Electromagnetic	
Motors	6.1	Drive motor rating S2 60 min	kW	0.65	
	6.2	Lift motor rating at S3 7,5%	kW	2.2	
	6.4	Battery voltage/nominal capacity K5	V/Ah	24 / 60	
	6.5	Battery weight +/- 5%	kg	19	
	6.6	Energy consumption acc. to EN16796 cycle	KWh/h	0.47	
Other	8.1	Type of drive control		DC Speed Control	
	8.4	Sound level at the driver's ear according to EN 12 053	dB(A)	<70	

Truck performance and dimensions are nominal and subject to tolerances.  
Toyota Material Handling products and specifications are subject to change without notice.

Mast Dimensions	SHE100			Duplex Tele	
	h23	Lift height (h13+h3)	mm	2900	3600
	h3	Lift	mm	2814	3514
	h1	Height, mast lowered	mm	1930	2280
	h2	Free Lift, ground to top of forks	mm	-	-
	h4	Height, mast extended	mm	3337	4037



Specification	SHE100
Service weight including battery	565 - 584 kg
Load Capacity	1000 kg
Height, fork lowered	86 mm
Overall length	1710 mm
Overall width	800 mm
Turning radius	1350 mm
Travel speed, with/without load	4.2/4.5 km/h
Drive motor rating S2 60 min	0.65 kW
Battery weight	19 kg
Sound level at the driver's ear according to EN 12 053	<70 dB(A)



Lithium-ion Battery for increased productivity



Pin Code for Access Control



Effortless Manoeuvrability, light and compact



Ergonomic Design perfect for confined areas

Distributor information