

Pedestrian stacker truck 1.2 ton

BT staxio

W-series

SWE120S



Pedestrian stacker straddle version

Specification for stacker trucks					SWE120S
Identification	1.1	Manufacturer			BT
	1.2	Model			SWE120S
	1.3	Drive			Electric
	1.4	Operator type			Pedestrian
	1.5	Load capacity/rated load	Q	kg	1200
	1.6	Load centre	c	mm	600
	1.8	Load distance, centre of support arm wheel to face of forks	x	mm	569
	1.9	Wheelbase	y	mm	1203
	Weight	2.1	Service weight including battery		kg
2.2		Axle load, with load, drive/support arm wheel		kg	635/1580
2.3		Axle load, without load, drive/support arm wheel		kg	675/340
Wheels	3.1	Drive/support arm wheel			Powerfriction/Vulkollan *)
	3.2	Wheel size, front		mm	Ø230x70
	3.3	Wheel size, rear		mm	Ø100x73
	3.5	Wheels, number front/rear (x=driven wheels)			1x/2
	3.7	Track width, rear	b_{11}	mm	1000
Dimensions	4.2	Height, mast lowered	h_1	mm	1832 *)
	4.3	Free lift	h_2	mm	1380 *)
	4.4	Lift	h_3	mm	2655 *)
		Lift height	h_{23}	mm	2655 *)
	4.5	Height, mast extended	h_4	mm	3226 *)
	4.8	Stand height (optional platform)	h_7	mm	150
	4.9	Height of tiller in drive position, min./max.	h_{14}	mm	865/1235
	4.10	Height of support arm	h_{10}	mm	100
	4.15	Height, fork lowered	h_{13}	mm	50
	4.19	Overall length	l_1	mm	1946
	4.20	Length to face of forks	l_2	mm	784
	4.21	Overall width	b_1/b_2	mm	770/1100 *)
	4.22	Fork dimensions	$s/e/l$	mm	40/100/1150 *)
	4.24	Fork-carriage width	b_3	mm	840
	4.25	Width over forks	b_5	mm	252—800
	4.26	Distance between support arms	b_4	mm	900 *)
	4.31	Ground clearance, with load, below mast	m_1	mm	32
4.32	Ground clearance, centre of wheelbase	m_2	mm	40	
4.33	Aisle width for pallets 1000x1200 crossways	A_{st}	mm	2292	
4.34	Aisle width for pallets 800x1200 lengthways	A_{st}	mm	2300	
4.35	Turning radius	W_a	mm	1353	
Performance data	5.1	Travel speed, with/without load		km/h	6/6
	5.2	Lift speed, with/without load		m/s	0.11/0.21
	5.3	Lowering speed, with/without load		m/s	0.33/0.24
	5.8	Max. gradeability, with/without load		%	8/10 ¹⁾
	5.10	Service brake			Electromagnetic
Electric motor	6.1	Drive motor rating S2 60 min		kW	1.0
	6.2	Lift motor rating at S3 15%		kW	2.2 ²⁾
	6.4	Battery voltage/nominal capacity K_s		V/Ah	24/225 *)
	6.5	Battery weight		kg	219 *)
	Others	8.1	Type of drive control		

¹⁾ Measured according to company standard

²⁾ S3 6%

*) Further alternatives are available and will produce other values.

Data is based on standard configurations: Medium battery compartment, h_{23} = 2655 mm Duplex HiLo mast.

Truck performance and dimensions are nominal and subject to tolerances. BT Products AB products and specifications are subject to change without notice.

Battery dependent dimensions

BT staxio

Dimensions		Battery Compartment		SWE120S	
				Medium	Large
1.9	Wheelbase	y	mm	1203	1253
4.19	Overall length	l ₁	mm	1946	1996
	without platform		mm	2031/2421	2081/2471
4.20	Length to face of forks	l ₂	mm	784	834
	without platform		mm	869/1259	919/1309
4.33	Aisle width for pallets 1000x1200 crossways	A _{st}	mm	2292	2343
	without platform		mm	2377/2777	2427/2827
4.34	Aisle width for pallets 800x1200 lengthways	A _{st}	mm	2300	2350
	without platform		mm	2386/2785	2435/2835
4.35	Turning radius	W _a	mm	1353	1403
	without platform		mm	1438/1838	1488/1888
6.4	Battery voltage, nominal capacity K ₅		V/Ah	24/225	24/300
6.5	Battery weight, min.—max.		kg	189—250	230—280

Mast dimensions

SWE120S		Simplex	Duplex Tele				Dupl. Tele Panor. View				Duplex HiLo				Triplex HiLo				
h ₂₃	Lift height (h ₁₃ +h ₃)	mm	1355	1655	2655	2855	3255	3655	4105	2655	2855	3255	3655	4105	3255	3655	4105	4455	4755
h ₃	Lift	mm	1305	1605	2605	2805	3205	3605	4005	2605	2805	3205	3605	4005	3205	3605	4005	4405	4705
h ₁	Height, mast lowered	mm	1822	2122	1837	1937	2137	2337	2562	1832	1932	2132	2332	2557	1692	1826	1976	2092	2192
h ₂	Free lift, ground to top of forks	mm	1355	1655	126	126	126	126	126	126	126	126	126	126	1380	1480	1680	1880	2104
h ₄	Height, mast extended	mm	1901	2201	3205	3405	3805	4205	4655	3205	3405	3805	4205	4655	3226	3426	3826	4226	4676

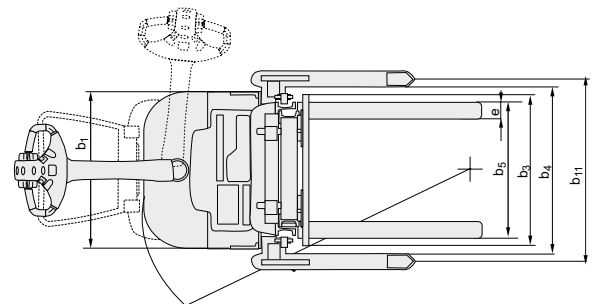
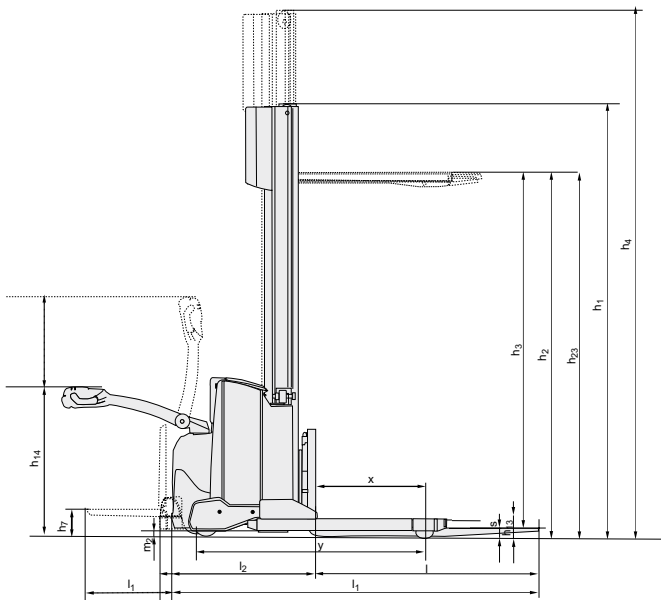

Truck features:

- BT Powerdrive System
- Fingertip controls
- Electronic braking system
- Electronic speed control
- Operator safety
- Storage compartments
- Automatic switch-off
- Click-2-creep
- Programmable performance
- Easy access for maintenance
- Built in charger (option)
- Sensilift (option)
- Flip-up operator platform (option)
- Toyota I_site: truck fleet management system (option)
- Hydraulic oil for low temperatures (option)

